

# Lifting table / Vehicle adapter

## Lifting Table

Art. No.	Product
600353	Scissor Table Z8805

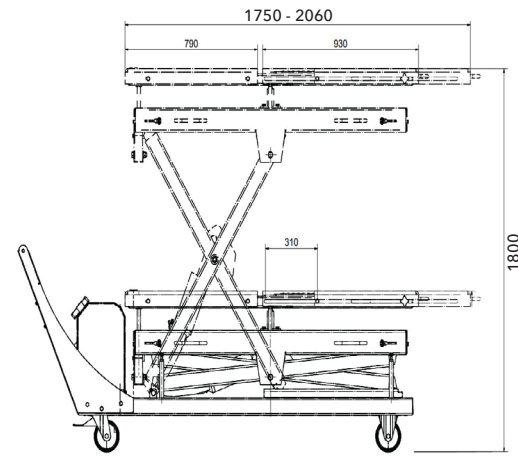

Heavy components, such as vehicle batteries, can be installed and removed safely and accurately with our mobile lifting table. The platform can be controlled 3-dimensionally to precisely reach the desired position.

### Equipment:

- Lifting capacity 1,5 t
- Lifting height 1.050 mm (= max. platform height 1.800 mm)
- Platform can be moved and controlled separately in 3 dimensions
- Fast and exact operation possible due to 2 lifting speeds

## Vehicle adapter

Many modern vehicles require adapted solutions for safe lifting. For this purpose, you will find an extensive range of such mounts for a wide range of vehicle types. Below you can see some selected examples.

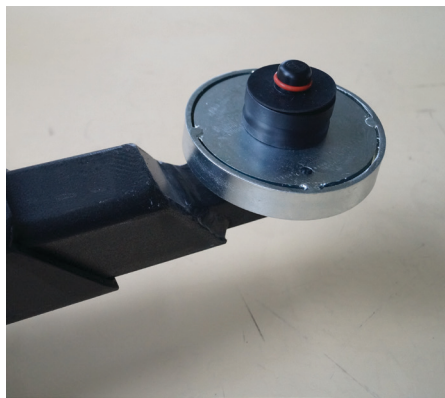

Adapter e.g. for Tesla-vehicles

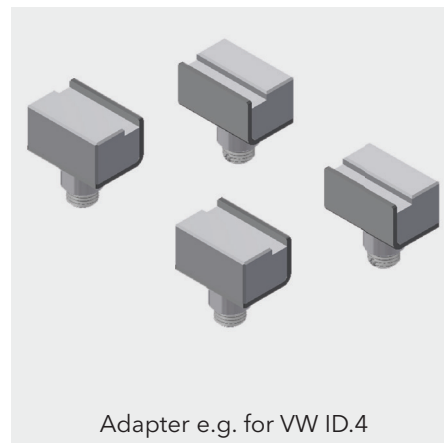

Adapter e.g. for VW ID.4



Adapter for lifting at the vehicle fold

\* Lifting heights only reachable with optional accessories  
 \*\* Lowest swivel-in heights reachable with optimal floor conditions

Printing errors, mistakes and technical changes reserved.  
 Illustrations can deviate from the products.



# SOLUTIONS FOR E-MOBILITY

**Consul Werkstattausrüstung GmbH**  
 Daimlerstr. 1  
 58553 Halver

Tel: +49 (0)2353 7009-0  
 Fax: +49 (0)2353 12515  
 E-Mail: info@consul-gmbh.com

**www.consul-gmbh.com**

Made in Germany



**CONSUL**®



## Swivel arms with interchangeable system

Art. No.	Product
707380	Swivel arms 3,5 t

suitable for:

Art. No.	Product
540609	Premium EL® 2.40
538322	HD FLEX® 2.40
590653	HD Pro 2.40

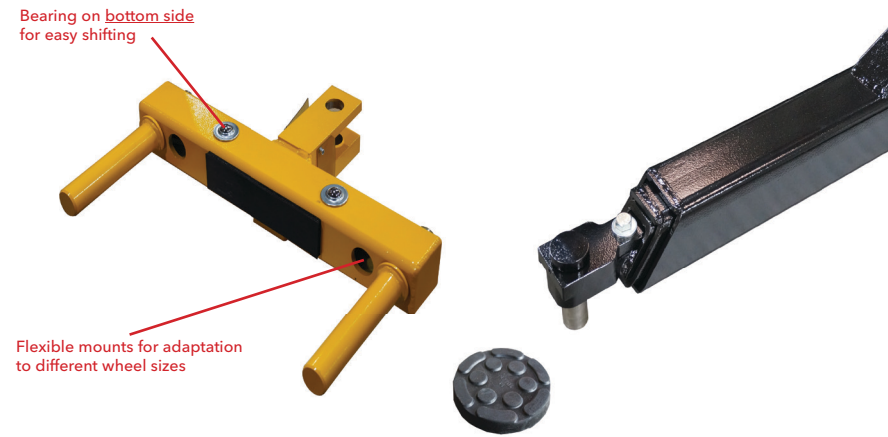
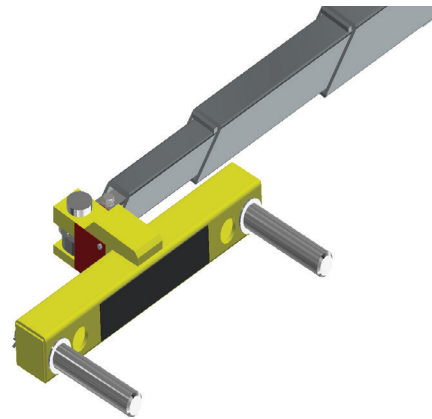

The swivel arms with interchangeable system allow vehicles to be picked up either at the pick-up points or at the wheels.

Due to the extended arms it is necessary to reduce the lifts maximum load capacity to 3.5 tons.

### Equipment:

- Swivel arms with interchangeable system Support plate / wheel gripper
- Capacity 3,5 t
- Maximum receivable wheelbase 3.300 mm
- Wheel grab system adaptable to different wheel sizes
- Bearings on the bottom side of the wheel grippers prevent grinding on the floor

## Lifts for electronic vehicles

Art. No.	Product
731547	Premium EL® 2.35 EV
731554	HD FLEX® 2.35 EV
731562	HD Pro 2.35 EV

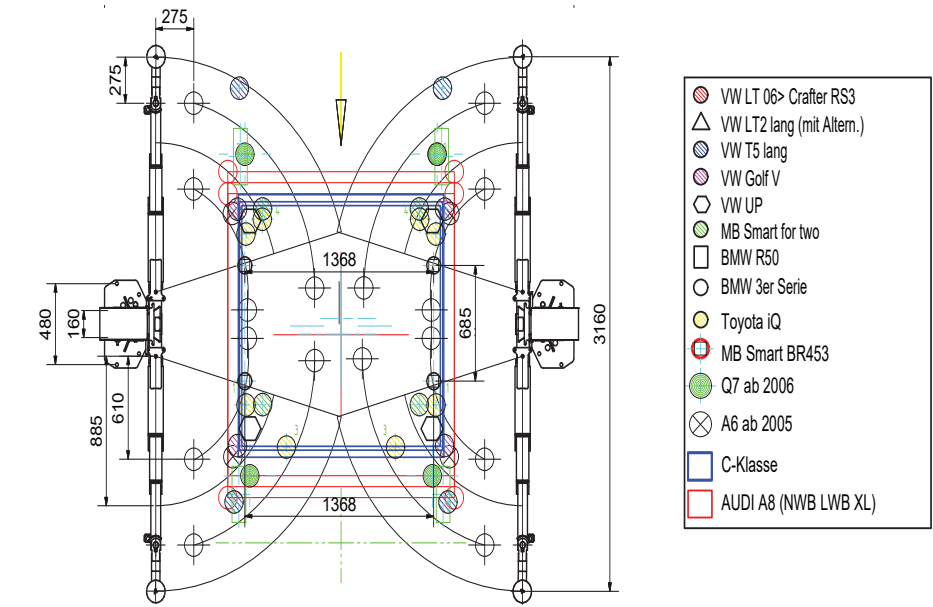

Lift with angled support arm ends for picking up vehicles even at hard-to-reach pick-up points. For electric vehicles, access to batteries and underbody is significantly improved.

### Equipment:

- Angled support arm ends for optimal access to battery / underbody
- Capacity 3,5 t
- Universal use for vehicles with electric or combustion engines

## Swivel arms with cranked mount

Art. No.	Product
673848	Swivel arms for e-vehicles

suitable for:

Art. No.	Product
540500	Premium EL® 2.35
547786	HD FLEX® 2.35
590604	HD Pro 2.35

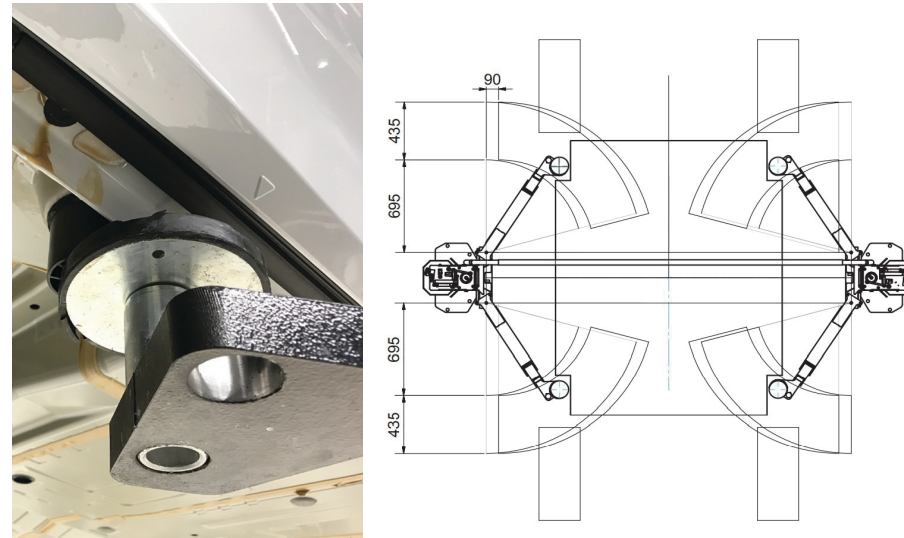
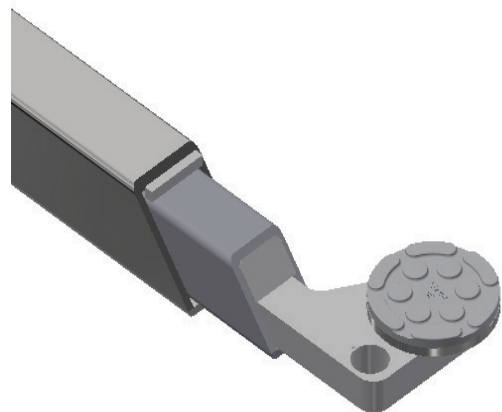

Swivel arms with cranked mount for better access to underbody panels or under-floor batteries. The platform can still be used for vehicles with combustion engines. The lifting capacity remains the same.

### Equipment:

- Swivel arm ends with cranked mount for optimal access to battery / underbody
- Capacity 3,5 t

## Double System Chassis

Art. No.	Product
647305	Double System Chassis

suitable for:

Art. No.	Product
577031	Premium EL® 2.45
588004	HD FLEX® 2.45
591776	HD Pro 2.45

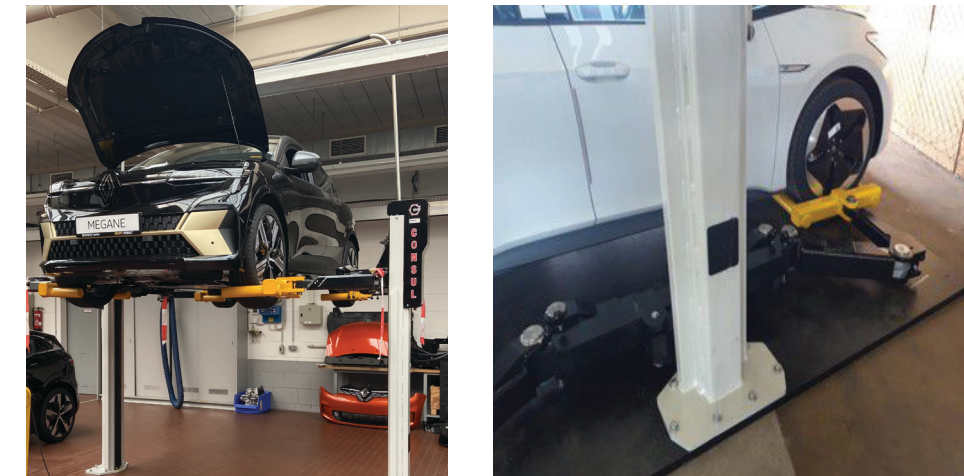

The double system chassis allows the vehicle to be supported either by swivel arms with plate mounts or arms with wheel grab system. No conversion is necessary for this. Unused mounts are folded away to save space.

In this way, versatile use of the platform is possible without requiring additional space.

### Equipment:

- Flexible lifting via pick-up plate or wheel grab system without conversion
- Capacity 3,5 t
- Fits vehicles from compact cars up to SUVs
- Problem-free retrofitting to existing platforms, column spacing remains the same